

1

2

3

4

D

D

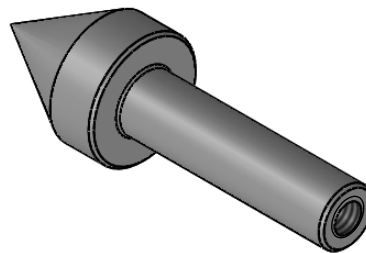

C

C

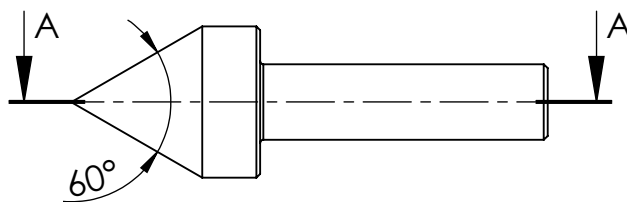

B

B

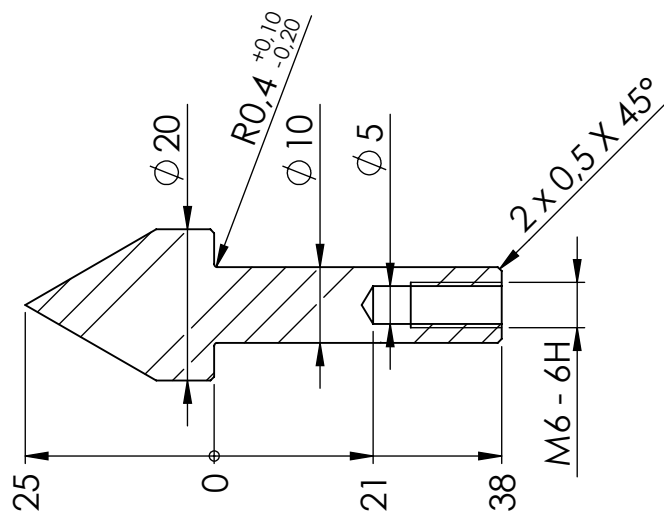

SCHNITT A-A

-	-	-	-	-
Index/Rev.	Beschreibung der Änderung / Revision Record	Datum	Bearb.	Gepr.

Fehlende Maße sind den CAD-Daten zu entnehmen / missing dimensions according to CAD-model

Werkstückkanten Edge finish	Allgemeintoleranzen General Tolerances	Werkstoff Material	M6-Stab 5846	Maßstab Scale	1:1
DIN ISO 13715		DIN ISO 2768-mK	Oberfläche Surface		
Schutzvermerk Protection marc	Datum	Name	Benennung / Name		Blatt Sheet
DIN ISO 16016	Bearb. 2016-10-14	HBU	Zentrierspitze		1
	Gepr. 2016-10-14	KJa			von/of
Projekt / Project	PKM-Engineering Hendrik Buchheister Rabenknapp 48 D-59581 Warstein-Belecke +49 (0) 176 32 81 49 17 info@pkm-engineering.de		Zeichnungsnr. / Drawingno.		Format
NX-16200	Projektion Projection		NX-16200-102-A		A4

1

2

3

4

A

A