

Designed in Eagle PCB

free from cadsoft

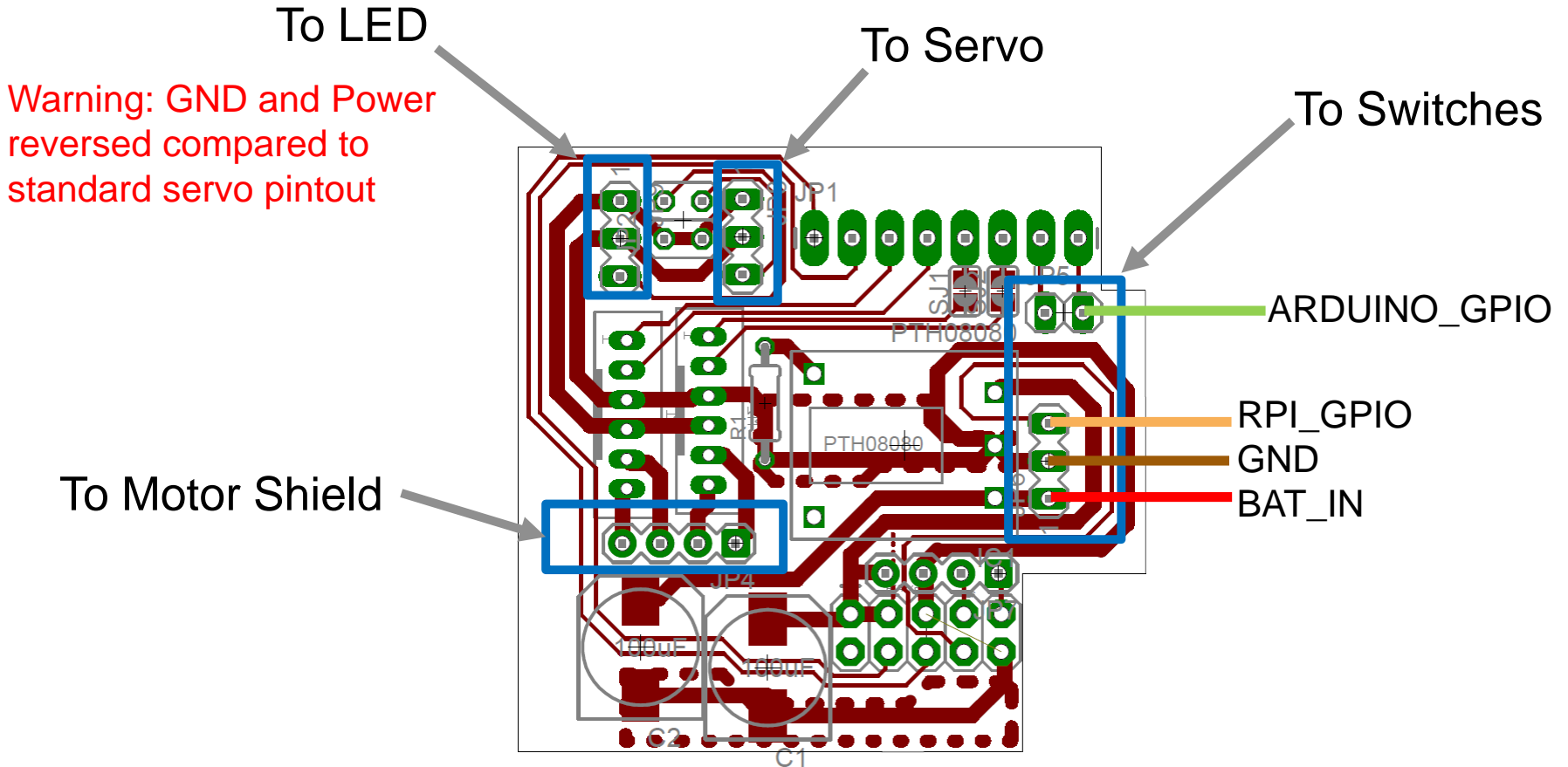

PCB Schematics

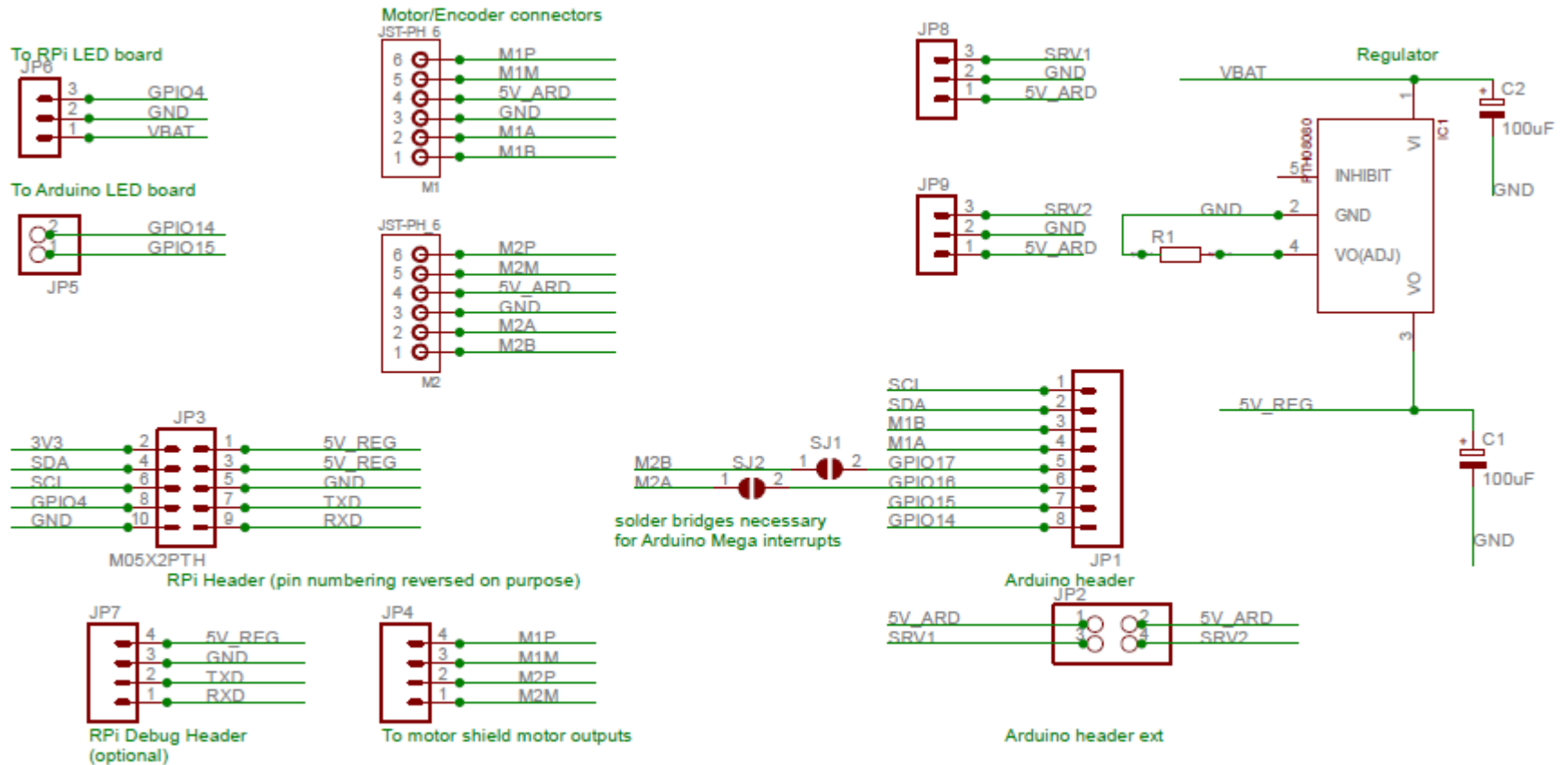

Example wiring

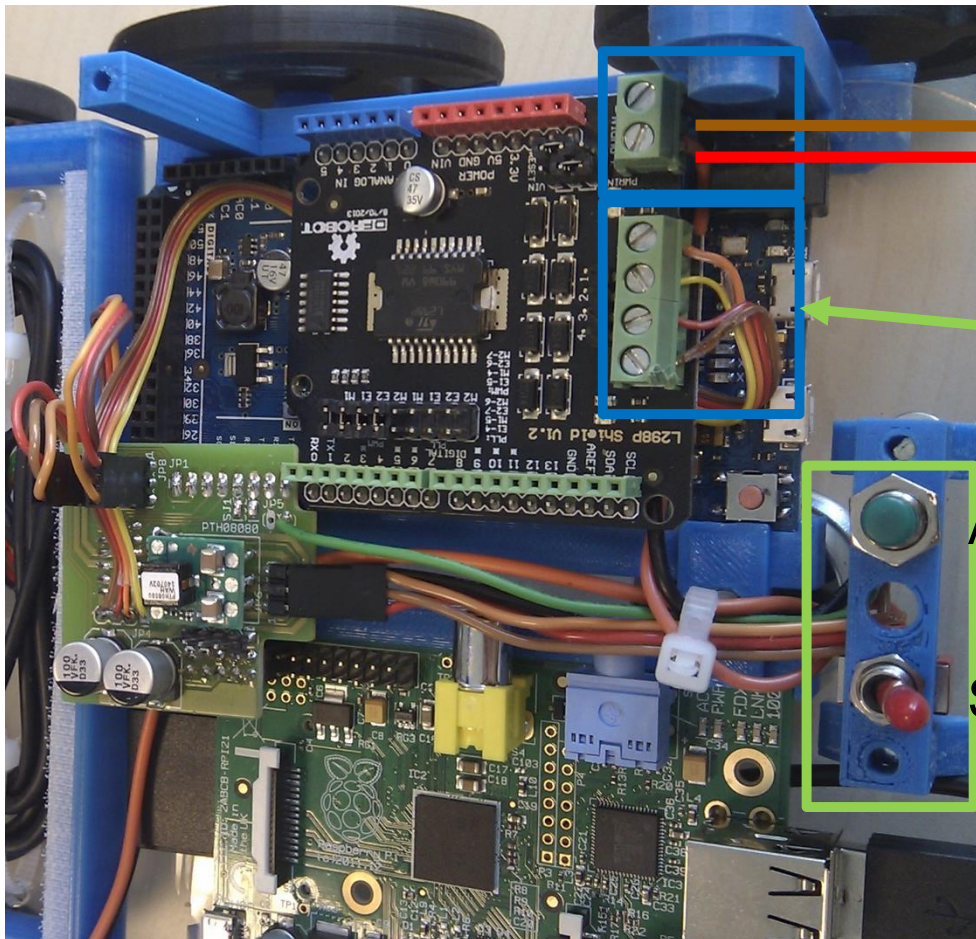

To switched BAT_IN

To PCB

Arduino pushbutton

Switch on BAT_IN

In this picture the raspberry pi pushbutton is not present – that's ok as it is not used in models (RPI_GPIO or GPIO4 on schematics)